

SECTION A-A

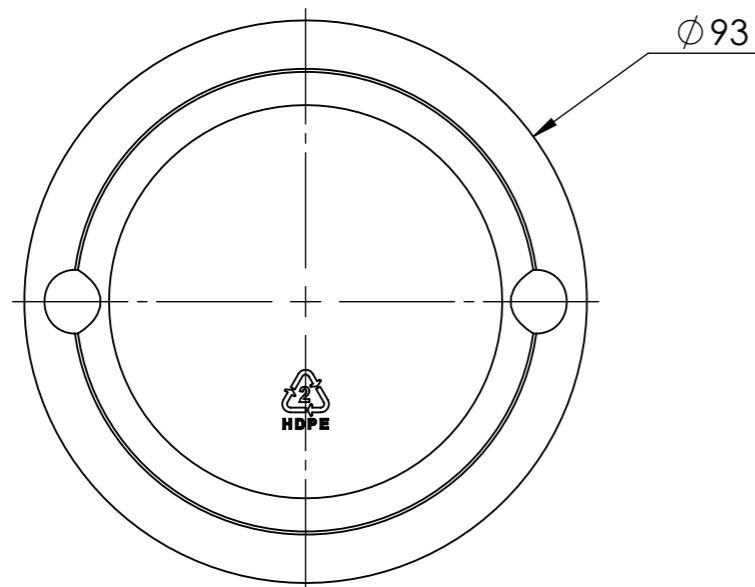

CHANGE DETAILS			DATE	BY	ISSUE
ALL DIMENSIONS IN mm			ELLAPACK Pty Ltd Blow Moulders of Plastic Containers and Technical Parts		
FINISH:	MATERIAL: HDPE	DRAWN: <i>George.K</i> www.cadcamservices.com.au			
COPYRIGHT THIS DRAWING IS CONFIDENTIAL AND MUST NOT BE COPIED OR DISCLOSED IN PART OR FULL WITHOUT CONSENT			CHECKED:	DATE: 02/04/26	
			PROJECTION: 3rd ANGLE	TOLERANCES: LINIER X ± 0.25 X.X ± 0.1 X.XX ± 0.05	
Brimful - 1100ml approx			TITLE: 1000 ML - JAR		
WEIGHT: 65 - grams est			SCALE:1:1	A3	DWG NO.